

267 Series - Nuclear Grade OFF-Delay Timer

5 & 10 Amp Contacts

- Nuclear Grade time delay relay - IMPROVED version of the popular 236 series. Timing circuit is made using a solid-state timing IC to achieve 3% repeatability over voltage and temperature range.

Note: Timing Module is not software programmed. The chips are hardware programmed. cannot be reprogrammed. See Page #3 of this Data Sheet for additional Module information and

- Base Relay is made from the 219 Series with contacts that can be configured up to 3PDT or 5PST.
- Both Standard and Sensitive Bifurcated contacts can be combined in the same relay.
- Locking Shaft potentiometer and integral locking clip are standard.
- Large option list makes this product easily customized for special application. Blow out magnets can be added to increase DC switching capability. 94V-O rated enclosure and materials.

GENERAL SPECIFICATIONS (@ 25° C)

Timing:

Functions Available	Off-delay,
Time Range	Up to 7 hours
Timing Adjustment	Locking shaft potentiometer
Timing Repeatability (Constant voltage and temperature)	3%
Reset Time maximum	150mS



Contacts:

Contact Configuration	DPDT, DPDT+NO, 3PDT
Contact Material	Silver Alloy Gold Diffused
Contact Rating	10 Amp (50mA min.) / 5 Amp
120 / 240VAC Resistive	10 Amp
28VDC Resistive	50 mA
Minimum Contact Load	
Motor 120VAC	500mW
Motor 240VAC	
Minimum Contact Load	
Contact Resistance, Initial	100 milliohms max @ 6VDC, 1A

See page 2 for additional options

See page 3 for additional contact ratings

Coil:

Coils Available	AC and DC
Nominal Coil Power	5VA 2.5W
Input Voltage Tolerance -AC	85% to 110% of nominal
Input Voltage Tolerance -DC	80% to 110% of nominal
Transient Protection	Yes
Reverse Polarity Protection	Yes
Duty	Continuous

Dielectric Strength:

Across Open Contacts	500Vrms
Between Mutually Insulated Points	1500Vrms
Insulation Resistance	1,000 Mohms min @ 500VDC

Temperature:

Operating	-20 to 70°C (-4 to 158°F)
Storage	-40 to 105°C (-40 to 221°F)

Life Expectancy:

Electrical (full load operations)	100,000
Mechanical (no load operations)	10,000,000

Miscellaneous:

Mounting Position	Any
Enclosure	Clear Polycarbonate
Weight	8.5oz (241 grams)
Mating Socket	12 PIN = 27390 (D)
	14 PIN = 33377 (D)
	(D) is option for DIN Rail Mount

Outline Dimensions

Dimensions shown in inches & (Millimeters)

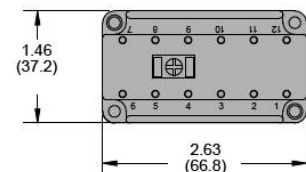
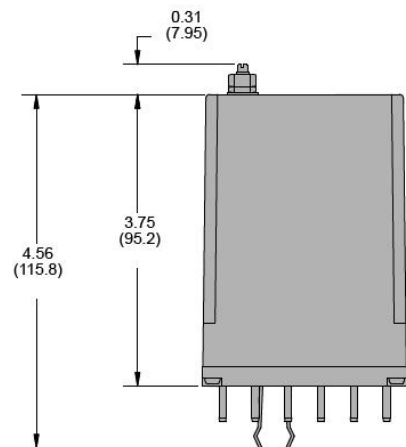

267 Series - Nuclear Grade OFF-Delay Timer 5 & 10 Amp Contacts

Ordering Code 267 ABX 69 P LM33V 010 120VAC

Series
267 - On delay

Contact Arrangement

ABX (1 N.O. + DPDT) 12-Pin
 XBX (DPDT) - (2 form C) 12-Pin
 XCX (3PDT) - (3 form C) 12-Pin
 BBX (2 N.O. + DPDT) 12-Pin
 BXB (2 N.O. + 2 N.C.) 12-Pin
 EXX(5PST) - (5 N.O.) 14-Pin

Construction

Blowout Magnet - 69
 Polycarbonate Cover - CODE P

Other Options

Lamp Indicator - L
 Manual Actuator - M
 Bifurcated Contacts - 33
 Coil Suppression Diode - V
 Cover Gasket - N

Timing Ranges

0.1 - 1 seconds - CODE 001
 1.0 - 10 seconds - CODE 010
 10 - 100 seconds - CODE 100
 100 - 1000 seconds - CODE 01K
 1000 - 10,000 seconds - CODE 10K
 Other timing ranges available

Operating Voltage

VAC: 6, 12, 24, 120, 208, 220, 240 (Add VAC)
 VDC: 12, 24, 48, 115-125 (Add VDC)

Use Code "69" for optional Blowout Magnet when switching voltages above 40VDC.

Use Code "33" for bifurcated contacts when switching low level current below 50mA up to 5 Amps.

Note: If both 10A and 5A "33" contacts are needed on the same relay a special part number will need to be assigned. To accomplish that, contact the factory directly through info@struthers-dunn.com

267 Wire Diagram

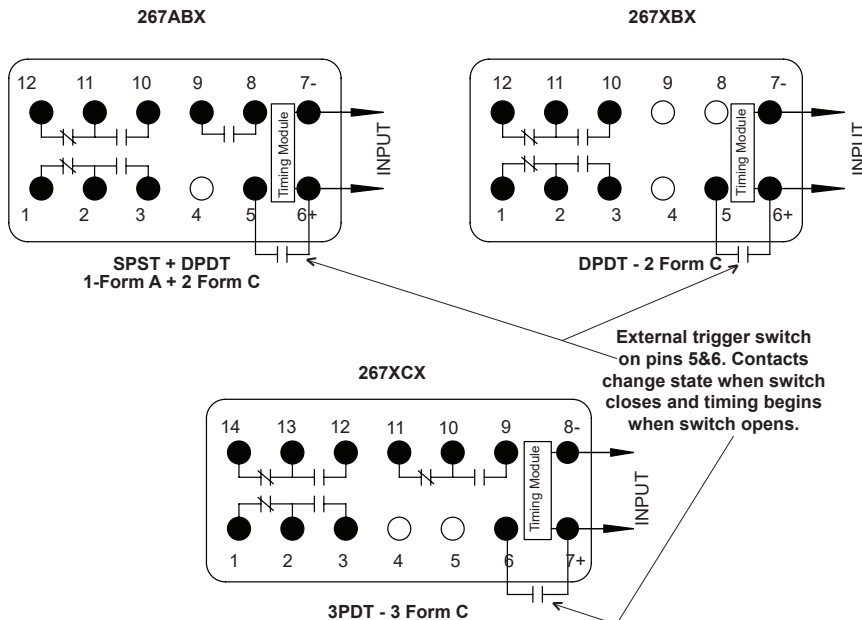

267 Series - Nuclear Grade OFF-Delay Timer 5 & 10 Amp Contacts

267 Series Coil Specifications

AC Coils, 50/60HZ				DC Coils				
Nominal voltage	Resistance ohms 10%	Milliamperes		Impedance ohms	Nominal voltage	Resistance ohms 10%	Milliamperes	
		Cold	Hot				Cold	Hot
6	1.1	1500	840	7.2	6	15.5	385	304
12	4.2	750	410	27	12	63.5	189	147
24	15.5	375	200	120	24	250	96	77
120	540	75	40	2700	48	975	49	39
240	2100	32	17	13400	115/125*	6200	20	16
					250	27777	9	7

Note: Standard 125VDC relays have nameplates stamped 115/125VDC. These relays operate at 80% of the lower voltages and operate within allowable temperature rises at higher voltages.

Standard Contact Load Ratings

Contact Configuration	Max Current / HP	Load Voltage	Load Voltage	Type of Load
All Styles EXCEPT Code 33	10 Amp 5 Amp 1/6HP 1/3HP	120 VAC 240 VAC 120 VAC 240 VAC	50/60Hz 50/60Hz 50/60Hz 50/60Hz	Resistive Resistive Motor Motor
Code 33	5 Amp 2.5 Amp	120 VAC 240 VAC	50/60Hz 50/60Hz	General Purpose General Purpose

Use Code "69" for optional Blowout Magnets when switching above 40VDC voltages.
Use Code "33" for bifurcated contacts when switching low level current below 50mA up to 5 Amps.

See Page 4 for Additional Lab-tested Contact Ratings

Questions and Answers Concerning the Security of the 267 Series Timer Electronics:

- Q. Is the solid-state timing IC CMOS or something else and, is it a Struthers-Dunn proprietary ASIC or off-the-shelf, etc?
A. CMOS - off the shelf. The timing circuit includes an IC with an internal binary counter employing digital logic gates.
- Q. Are there any microprocessors or microcontrollers?
A. No
- Q. Are there any programmable logic devices (CPLD, FPGA, etc.)?
A. No
- Q. Are there any memory devices (flash, EEPROM, etc.)?
A. No
- Q. Are there any ASICs?
A. No
- Q. What does "hardware programmed" mean?
A. No software. Programmed by IC Pins tied to either HI or LO and external resistor/capacitor (external to IC but internal to the timer module/relay.)
- Q. Are there any oscillators inside the device? This includes crystal oscillators, free- running RC oscillators, switching power modules, and anything that could generate high-frequency noise?
A. The IC has an internal oscillator controlled by an external R/C network. The frequency will vary according to the R/C values. Typically: 2Hz to 4KHz. The shorter the timing, the higher the frequency.

267 Series - Nuclear Grade Time Delay Relay Up To 5 & 10 Amp Contacts

Below are optionally lab-tested contact load factors based on switching configurations and various Voltage/Current loads that are for reference only. (Not official UL ratings)

Highest Load for Standard Contacts

*Current - A, Resistive unless otherwise noted

Voltage	Current, A	Switching Type
28 VDC, "69"	10A	Make & Break
48 VDC, "69"	10A	Make & Carry
	5A	Make & Break
125 VDC, "69"	10A	Make & Carry
	4A	Carry & Break
	3A	Make & Break
250 VDC, "69"	4A	Make & Carry
	2A	Carry & Break
	1A	Make & Break
120 VAC	10A, 3A Inductive, 1/6 HP	Make & Break
240 VAC	10A, 1/3 HP	Make & Break
277 VAC	10A	Make & Carry
	7A	Carry & Break
	4.5A	Make & Break

Lowest Load for Bifurcated Contacts

*Current - A, Resistive unless otherwise noted

Voltage	Current, A	Switching Type
5 VDC	0.1A	Make & Break
12 VDC	0.075A	Make & Break
28 VDC	0.01A	Make & Break
48 VDC	0.005A	Make & Break
125VDC	0.005A	Make & Break
250 VDC	0.001A	Make & Break
120 VAC	0.01A	Make & Break
240 VAC	0.005A	Make & Break
480 VAC	0.001A	Make & Break

Lowest Load for Standard Contacts

*Current - A, Resistive unless otherwise noted

Voltage	Current, A	Switching Type
5 VDC	1A	Make & Break
12 VDC	0.75A	Make & Break
28 VDC	0.050A	Make & Break
48 VDC	0.050A	Make & Break
125VDC	0.050 A	Make & Break
250 VDC	0.050A	Make & Break
120 VAC	0.050A	Make & Break
240 VAC	0.050A	Make & Break
480 VAC	0.050A	Make & Break

Highest Load for Bifurcated Contacts

*Current - A, Resistive unless otherwise noted

Voltage	Current, A	Switching Type
28 VDC	5A	Make & Carry
	3A	Carry & Break
	2.5	Make & Break
48 VDC	3A	Make & Carry
	2A	Carry & Break
	1.5A	Make & Break
150VDC	1A	Make & Carry
	0.5	Carry & Break
250 VDC	0.25	Make & Break
	0.5A	Make & Carry
	0.25A	Carry & Break
120 VAC	0.1A	Make & Break
	5A	Make & Carry
	3A	Carry & Break
240 VAC	5	Make & Break
	2.5A	Make & Carry
	1.5A	Carry & Break
277 VAC	2.5 A	Make & Break
	2.5A	Make & Carry
	1.5A	Carry & Break
480 VAC	1.0A	Make & Break
	0.5A	Make & Carry
	0.2A	Make & Break

Bifurcated Contacts - Explanation

What are the advantages of Bifurcated contacts?

Bifurcated contacts are a set of contacts that are on a blade that is split into two parts. (See Photo)

Advantages: Bifurcated contacts are used specifically for low-level switching of current and voltages that are not reliably possible with standard contacts. The bifurcated contacts provide an increased amount of contact surface to transfer low-current signals with greater reliability.

The contacts can be set up like regular contacts **in any combination** with Normally Closed and/or Open contacts. The blades with the "dual contacts" move simultaneously to make contact with the Open and Closed set of contacts - just like Standard contacts.

Bifurcated contacts can be in a separate relay by themselves using the **Code 33** in the part number (See Pg. 2 for Ordering Codes) or combined in a relay alongside standard contacts. Relays with dual-type contacts are given special part numbers that would need to be assigned to ensure future compliance if replacements are needed.

Example of what Bifurcated contacts look like.

